



Kingfisher

Rubber & Plastics

Market Leaders in the
Rubber & Plastics Industry



MOTORHOME



FABRICATION



AGRICULTURE



TRAM & RAIL



BUS & COACH



CLASSIC CARS



MARINE



SPORTS & LEISURE



AEROSPACE



AUTOMOTIVE



3-8	EDGE TRIMS & DOOR SEALS
9-11	SPONGE EXTRUSIONS & CORD
12-14	GLAZING SECTIONS & FILLER STRIPS
15-18	RUBBER & PVC EXTRUSIONS
19	FLOCKED SECTIONS
20-27	FLOORING & MATTING
28	BESPOKE MANUFACTURING
29	GOOP, ADHESIVES & TOOLS
30 -31	GASKETS, STRIPS & SHEETS
32	INDUSTRY SECTORS
33	TOLERANCE CHARTS
34	CONVERSION CHARTS
35	MINI & CLASSIC CAR PARTS
36 - 37	ADDITIONAL INFORMATION

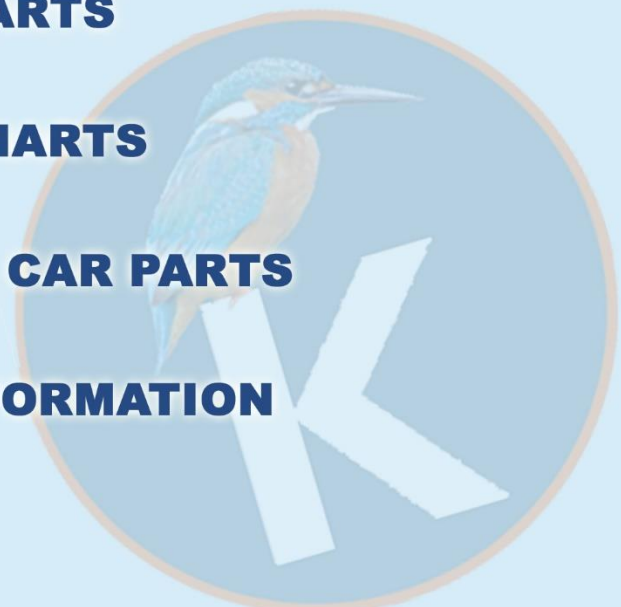



seal the deal with a name you can trust



Established in 1987 to provide high quality products with on-time deliveries to customers.

Kingfisher Rubber and Plastics, a family owned business, has progressively grown to become a market leading supplier in Seals, Extrusions, Edge Trims and associated products. Our customers span a wide range of industries from automotive, bus and coach manufacturers to aerospace and lighting specialists.

We hope you find everything you are looking for in this brochure, If not please get in touch with one of our sales team, we will be more than happy to help.



(+44) 01527 570 570

Telephone lines are monitored Monday - Thursday 08:00 - 17:00 and Fridays 08:00 - 13:00, with an answer phone at all other times.



sales@kingfisherrubber.co.uk

E-mails are constantly monitored and urgent emails will be actioned as soon as possible.



www.kingfisherrubber.co.uk

A bunch of really useful information can be found on our website. You can request samples, place orders, download datasheets and even start a chat with one of our sales team.



Kingfisher Rubber & Plastics

Units 1&2 Woden Court

Saxon Business Park

Bromsgrove

Worcestershire

B60 4AD

This is the best way to send us samples of parts you either need us to match up with our stock items, or for us to look at back engineering and reproduce for you.

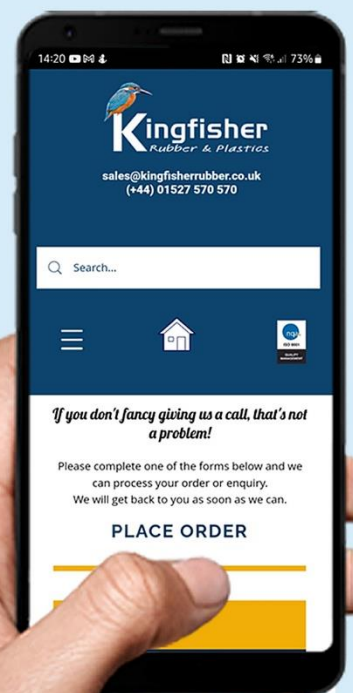

Scan here to place an order

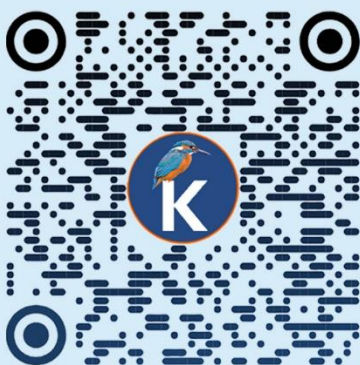



seal the deal with a name you can trust

Door Seals & Edge Trims

Our Edge Trims & Door Seals make for optimal coverings for panels from 1mm - 8mm, with self gripping characteristics. The soft lip or bulb will ensure an effective seal when used on applications such as doors, lockers and enclosures.

KR 001

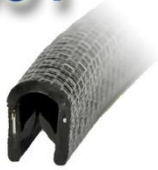
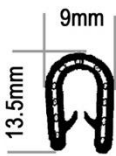

Panel
1.5mm - 3mm

50m Coils, Per Meter
& Cut Lengths

PVC &
Steel Clip

KR 002/R

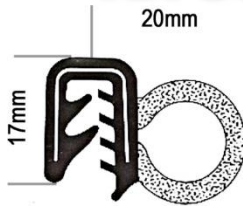

1.5mm - 3mm
Panel

50m Coils, Per Meter
& Cut Lengths

EPDM Solid & Sponge
Steel Wire Insert

KR 003



1mm - 3mm
Panel

50m Coils, Per Meter
& Cut Lengths

EPDM Solid & Sponge
Steel Wire Insert

KR 004

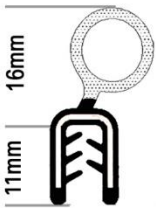

1mm - 3mm
Panel

50m Coils, Per Meter
& Cut Lengths

EPDM Solid & Sponge
Steel Wire Insert

KR 005

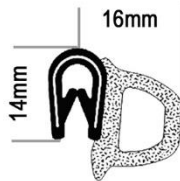

1mm - 3mm
Panel

50m Coils, Per Meter
& Cut Lengths

PVC carrier
Sponge Bulb. Steel Clip

KR 006

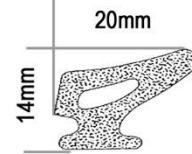

11.5mm
Base

50m Coils, Per Meter
& Cut Lengths

Single Density
EPDM Sponge

KR 007

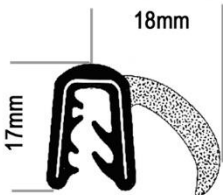

1mm - 3mm
Panel

50m Coils, Per Meter
& Cut Lengths

EPDM Solid & Sponge
Steel Wire Insert

KR 008



1mm - 3mm
Panel

50m Coils, Per Meter
& Cut Lengths

EPDM Solid & Sponge
Steel Wire Insert

KR 009



1mm - 3mm
Panel

50m Coils, Per Meter
& Cut Lengths

EPDM Solid & Sponge
Steel Wire Insert

Door Seals & Edge Trims

KR 010



16mm
13mm



1.5mm - 3mm
Panel

25m Coils, Per Meter & Cut Lengths

PVC Carrier & EPDM Sponge Bulb. Steel Clip

KR 011



26mm
16mm



1.5mm - 3mm
Panel

50m Coils, Per Meter & Cut Lengths

EPDM Solid & Sponge Steel Wire Insert

KR 112



13mm
10mm



1.5mm - 3mm
Panel

50m Coils, Per Meter & Cut Lengths

EPDM Steel Wire Insert

KR 113



11mm
16mm



1.5mm - 4mm
Panel

50m Coils, Per Meter & Cut Lengths

PVC & Steel Clip Insert

KR 115



20mm
17mm



4mm - 6mm
Panel

50m Coils, Per Meter & Cut Lengths

EPDM Sponge & Solid Steel Wire Insert

KR 116



12.5mm
12mm



1mm - 3mm
Panel

50m Coils, Per Meter & Cut Lengths

EPDM Solid & Sponge Steel Wire Insert

KR 117



16mm
14mm



1.5mm - 3mm
Panel

50m Coils, Per Meter & Cut Lengths

EPDM Solid & Sponge Steel Wire Insert



Door Seals & Edge Trims

<h3>KR 118</h3> <p>FURFLEX</p> <p>21mm 17mm</p> <p>2mm - 4mm Panel</p> <p>50m Coils, Per Meter & Cut Lengths</p> <p>EPDM Solid & Sponge Steel Wire Insert</p>	<h3>KR 119</h3> <p>10.5mm 10mm</p> <p>1mm - 3mm Panel</p> <p>50m Coils, Per Meter & Cut Lengths</p> <p>EPDM Solid & Sponge Steel Wire Insert</p>	<h3>KR 020</h3> <p>7mm 9mm</p> <p>1mm - 2mm Panel</p> <p>50m Coils, Per Meter & Cut Lengths</p> <p>PVC Steel Clip Insert</p>
---	--	--

KR 022

41mm
12mm

1.5mm - 3.5mm Panel

25m Coils, Per Meter & Cut Lengths

Single Density EPDM Steel Wire Insert

KR 024

13mm
15mm

4mm - 6mm Panel

50m Coils, Per Meter & Cut Lengths

PVC Steel Clip Insert

KR 027

9mm
14mm

1.5mm - 3.5mm Panel

50m Coils, Per Meter & Cut Lengths

EPDM Steel Wire Insert

KR 028

25mm
25mm
11mm

1mm - 2.5mm Panel

50m Coils, Per Meter & Cut Lengths

EPDM Solid & Sponge Steel Wire Insert

KR 029

16.5mm
17mm

9mm Base

50m Coils, Per Meter & Cut Lengths

EPDM Solid & Sponge

KR 031

23mm
10mm

1.5mm - 3.5mm Panel

50m Coils, Per Meter & Cut Lengths

EPDM Solid & Sponge Steel Wire Insert

KR 032

16mm
13mm

4mm - 6mm Panel

50m Coils, Per Meter & Cut Lengths

EPDM Solid & Sponge Steel Wire Insert

Drawings are to scale



seal the deal with a name you can trust



Door Seals & Edge Trims

KR 035



29mm

18mm

1.5mm - 3.5mm Panel

50m Coils, Per Meter & Cut Lengths

EPDM Solid & sponge wire insert

KR 036



10mm

6mm

1.5mm - 3.5mm Panel

50m Coils, Per Meter & Cut Lengths

EPDM Solid & Sponge Steel Wire Insert

KR 037



31mm

15mm

3mm - 5mm Panel

50m Coils, Per Meter & Cut Lengths

EPDM Solid & sponge wire insert

KR 038



20mm

14mm

1.5mm - 3.5mm Panel

50m Coils, Per Meter & Cut Lengths

PVC Solid EPDM Sponge Steel Clip Insert

KR 039



17mm

17mm

8mm - 10mm Panel

50m Coils, Per Meter & Cut Lengths

PVC Steel Clip Insert

KR 040



12mm

11mm

1mm - 2mm Panel

50m Coils, Per Meter & Cut Lengths

EPDM Solid & Sponge Steel Wire Insert

KR 041



32mm

16mm

1mm - 3mm Panel

50m Coils, Per Meter & Cut Lengths

EPDM Solid & Sponge Steel Wire Insert





seal the deal with a name you can trust

Door Seals & Edge Trims

KR 042



20mm
16mm



1.5mm - 3mm Panel

50m Coils, Per Meter & Cut Lengths

EPDM Solid & Sponge Steel Wire Insert

KR 044



33mm
10mm



1.5mm - 2mm Panel

50m Coils, Per Meter & Cut Lengths

EPDM Solid Steel Wire Insert

KR 047



35mm
14mm



2mm - 5mm Panel

50m Coils

Single Density EPDM Solid Steel Wire Insert

KR 046



19mm
18mm



3mm - 5mm Panel

50m Coils, Per Meter & Cut Lengths

EPDM Solid & Sponge Steel Wire Insert

Other Camper Conversion Parts

KRPS



Puddle Step
For the VW T5 sliding door step extra deep step with no light

KRTS / B



Rear Threshold Step
VW T5 (Barn Door)
Includes caps for screw holes

KRTS / T



Rear Threshold Step
VW T5 (Single Door)
Includes caps for screw holes

Other relevant parts such as Edge Trims, Extrusions and Flooring can be found on pages 3-8, 15-18 and 20-27

KR 049
VW T5 Front & Sliding Door Seal



KR 050
VW T5 Rear Boot Seal. Tailgate & Barn Door



KR 051
VW T4 Barn Door & Tail Gate



KR 052
VW T4 Sliding Door Seal



Available in 50m Coils

EPDM Solid & Sponge Steel Wire Insert

Door Seals & Edge Trims

KR 054

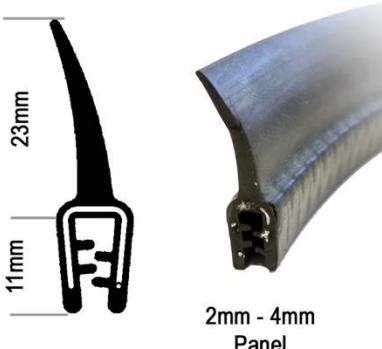

23mm
11mm
2mm - 4mm Panel

Available in 50m Coils EPDM Solid Steel Wire Insert

KR 055



10.5mm 9.5mm
1.5mm - 4mm Panel

Available in 50m Coils EPDM Solid Steel Wire Insert

KR 056



10mm 11mm
3mm - 6mm Panel

50m Coils, Per Meter & Cut Lengths EPDM Solid & Sponge Steel Wire Insert

KR 057



12mm
10mm
1.5mm - 3.5mm Panel

Available in 50m Coils EPDM Solid & Sponge Steel Wire Insert

KR 058



8.7mm
9.7mm
1.5mm - 3mm Panel

Available in 50m Coils EPDM Solid & Sponge Steel Wire Insert

Cut Lengths & Fabrication

As well as supplying seals in standard lengths, we offer a cutting and fabrication service.

Many of our customers have benefited from having parts supplied in pre-cut, ready to apply lengths, thus saving them valuable time on the shop floor.

Depending on the profile required, we can also manufacture mitred hatch seals, cabinet seals, door seals, picture frame seals and window seals, for either single one off projects, or bulk requirements.





Sponge Extrusions

Our range of sponge rubber sections are ideal for various applications. Some are Self Adhesive Backed, any sections that are not adhesive backed can be bonded in place with contact adhesive.

KRS 2



8mm
8mm

Available in 50m coils, Per Mtr & Cut Lengths

EPDM Sponge Extrusion

KRS 6



25mm
25mm

Available in 30m coils

EPDM Sponge Extrusion

KRS 8



26mm
30mm

Available in 20m coils

EPDM Sponge Extrusion

KRS 9



18mm
20mm

Available in 30m coils

EPDM Sponge Extrusion

KRS 11
SELF ADHESIVE



15mm
14mm

Available in 50m coils

EPDM Sponge Extrusion

KRS 14



14mm
14mm

Available in 50m coils

EPDM Sponge Extrusion

KRS 15
SELF ADHESIVE



5mm
9mm

Available in 100m coils

EPDM Sponge Extrusion

KRS 16
SELF ADHESIVE



6mm
9mm

Available in 100m coils

EPDM Sponge Extrusion

KRS 17
SELF ADHESIVE



10mm
8mm

Available in 50m coils

EPDM Sponge Extrusion

Sponge Extrusions

KRS 18
SELF ADHESIVE

8mm
10mm



Available in
100m coils

EPDM Sponge
Extrusion

KRS 19
SELF ADHESIVE

8mm
15mm



Available in
50m coils

EPDM Sponge
Extrusion

KRS 20
SELF ADHESIVE

10mm
12mm



Available in
50m coils

EPDM Sponge
Extrusion

KRS 21
SELF ADHESIVE

4mm
15mm



Available in
50m coils

EPDM Sponge
Extrusion

KRS 22
SELF ADHESIVE

18mm
21mm



Available in
25m coils

EPDM Sponge
Extrusion

KRS 23
SELF ADHESIVE

18mm
12mm



Available in
50m coils

Dual Density
EPDM Extrusion

KRS 24
24A1351

14mm
21mm



Available in
3475mm lengths

EPDM Solid & Sponge
Extrusion

KRS 25
14A6584

14mm
20mm



Available in
2430mm Lengths

EPDM Sponge
Extrusion

KRS 26
SELF ADHESIVE

12mm
14mm



Available in
30m coils

EPDM Sponge
Extrusion



Sponge & Solid Cord

Closed Cell Neoprene and Commercial Quality cord is available in many different diameters from 3mm - 25mm. Our cord is used in many different applications due to its properties and specifications, either supplied in straight lengths or fabricated into rings.

NEOPRENE SPONGE CORD			
Product Code	Cord Diameter (mm)	Available in coils of	Available by the Metre
KRNC 3	3	750m	✓
KRNC 4	4	1000m	✓
KRNC 5	5	750m	
KRNC 6	6	500m	✓
KRNC 8	8	300m	
KRNC 10	10	200m	
KRNC 12	12	50m	✓
KRNC 16	16	50m	✓
KRNC 19	19	25m	✓
KRNC 25	25	25m	✓

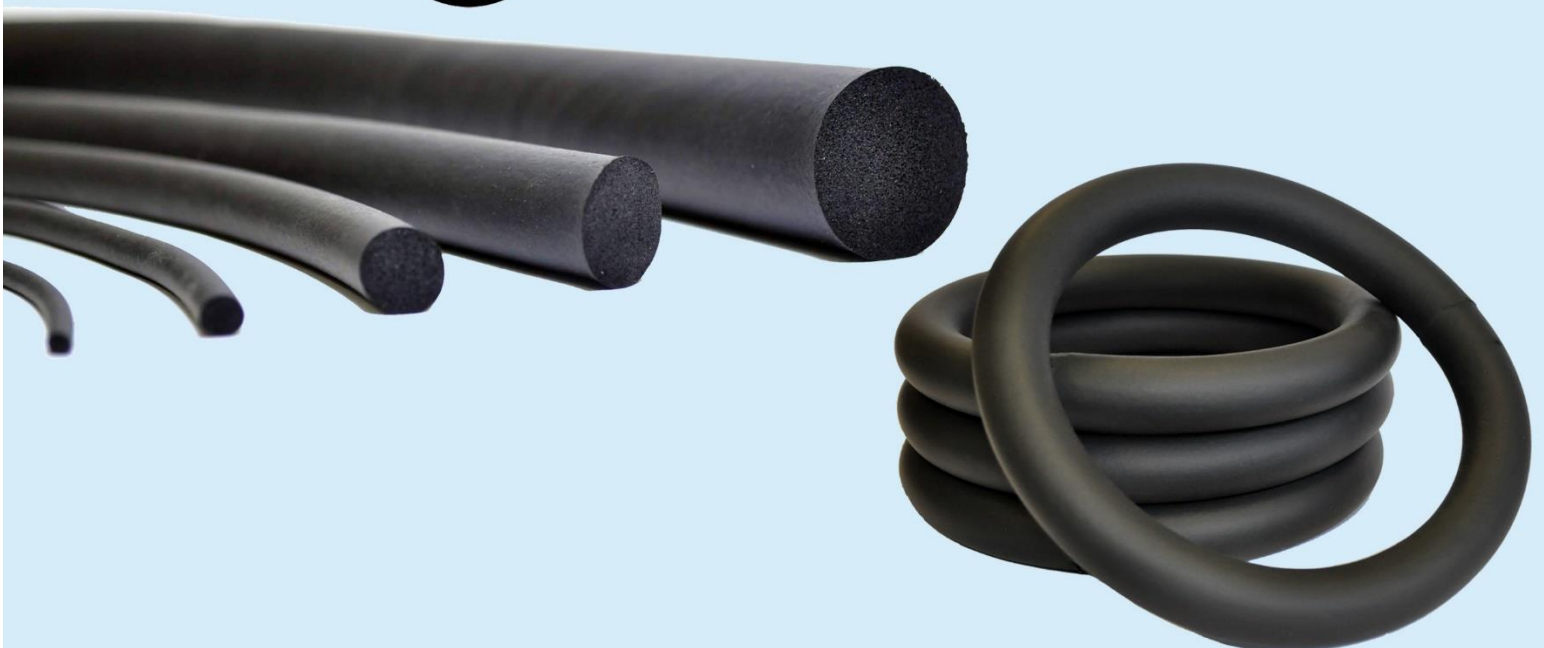

Glazing Sections

Our glazing sections are manufactured from either EPDM or PVC, both of which have great UV and weather resistant properties. Used in a multitude of applications such as land and marine vehicles, buildings and enclosures. These seals offer a quick and easy replacement of broken or damaged windows and panels.

Do not forget to order the filler strip and the glazing tool to fit your rubber. To find your required size measure your glass and panel thickness and check against the sections below.

All dimensions are in mm

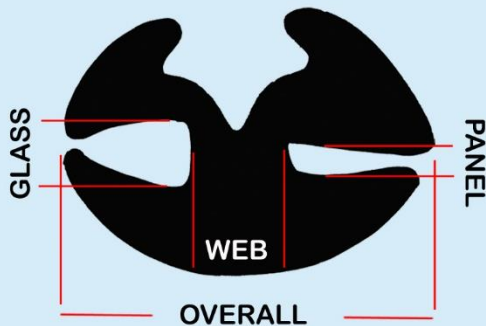

KR 255/E



Glass: 5mm Panel: 2mm Web: 6mm

30m Coils, Per Meter & Cut Lengths

EPDM Glazing Rubber

KR 256



Glass: 6mm Panel: 3mm Web: 7mm

30m Coils, Per Meter & Cut Lengths

PVC Glazing Rubber

KR 256/E



Glass: 6mm Panel: 3mm Web: 7mm

30m Coils, Per Meter & Cut Lengths

EPDM Glazing Rubber

KR 290/E



Glass: 6mm Panel: 6mm Web: 7mm

30m Coils, Per Meter & Cut Lengths

EPDM Glazing Rubber

KR 291



Glass: 5mm Panel: 5mm Web: 6mm

30m Coils, Per Meter & Cut Lengths

PVC Glazing Rubber

Glazing Sections

<p>KR 291/E</p> <p>20.5mm</p>  <p>Glass: 5mm Panel: 5mm Web: 6mm</p> <p>30m Coils, Per Meter & Cut Lengths</p> <p>EPDM Glazing Rubber</p>	<p>KR 292/E</p> <p>20.5mm</p>  <p>Glass: 3.5mm Panel: 3mm Web: 4.5mm</p> <p>30m Coils, Per Meter & Cut Lengths</p> <p>EPDM Glazing Rubber</p>
<p>KR 294/E</p> <p>23mm</p>  <p>Glass: 5mm Panel: 6mm Web: 7mm</p> <p>30m Coils, Per Meter & Cut Lengths</p> <p>EPDM Glazing Rubber</p>	<p>KR 343/E</p> <p>25mm</p>  <p>Glass: 4mm Panel: 3mm Web: 7mm</p> <p>30m Coils, Per Meter & Cut Lengths</p> <p>EPDM Glazing Rubber</p>
<p>KR 385/E</p> <p>27.2mm</p>  <p>Glass: 6mm Panel: 2mm Web: 8mm</p> <p>30m Coils, Per Meter & Cut Lengths</p> <p>EPDM Glazing Rubber</p>	<p>KR 6710/E</p> <p>30mm</p>  <p>Glass: 6mm Panel: 3mm Web: 8mm</p> <p>30m Coils, Per Meter & Cut Lengths</p> <p>EPDM Glazing Rubber</p>

Drawings are to scale





seal the deal with a name you can trust

Glazing Sections & Filler Strips

Our range of filler strips go hand in hand with our glazing sections.

Made from either EPDM or rigid PVC, we stock a wide selection to suit many glazing sections and vehicle rubbers. All of the below are supplied in 30m coils, or at cut lengths if required.

PART NUMBER	DRAWING	WEIGHT (Kg)	WIDTH	HEIGHT
KR 240		3	13mm	10mm
KR 241		2	10mm	8mm
KR 241/R		2	10mm	8mm
KR 242		2	7.4mm	5.5mm
KR 328 CHROME		1.7	10.7mm	8.8mm
KR 380 CHROME		1.7	11mm	6.7mm
KR 436 CHROME		1.7	10.5mm	8mm
KR 487 CHROME		1.7	14.5mm	5mm
KR 517 CHROME		2	8mm	6.7mm

Drawings are to scale



Window fitting tools are also available. Please order using product code 'KRT 101'



seal the deal with a name you can trust



Rubber & PVC Extrusions

Extrusions are used for a huge range of applications. Here you'll find various profiles from 'U' channels and tank straps to 'S' type rubbers and tadpole sections. We also stock parts for marine window applications, classic cars and many other industries.

KRE 704

Available in 30m coils EPDM Solid

KRE 705

Available in 50m coils EPDM Solid

KRE 708

Available in 30m coils EPDM Solid

KRE 712

50m Coils, Per Meter & Cut Lengths EPDM solid

KRE 713
BROWN BUBBLE SEAL

Available in 50m Coils Brown EPDM Solid

KRE 714

Available in 50m Coils EPDM Solid

KRE 715

Available in 50m coils EPDM Solid

KRE 716

Available in 100m coils EPDM Solid

KRE 717

Available in 50m Coils EPDM Solid

KRE 718

Supplied in 100m Coils EPDM Solid

KRE 721

Available in 100m Coils EPDM Solid



Rubber & PVC Extrusions

KRE 722

43mm
9mm
33mm

Available in 50m Coils EPDM Solid

KRE 723

12mm
12mm

Available in 50m Coils EPDM Solid

KRE 724

10mm
5mm

Available in 100m Coils EPDM Solid

KRE 725

18mm
15mm

Available in 50m coils EPDM Solid

KRE 727

35mm
8mm

Available in 50m Coils Nitrile Solid

KRE 729

28mm
22mm

Available in 25m Coils EPDM Solid

KRE 735

24mm
20mm

Supplied in 1m Lengths Solid PVC Flocked

KRE 736

16mm
18mm

Supplied in 1m Lengths Solid PVC Flocked

KRE 737

8mm
12mm

Available in 50m coils EPDM Solid

KRE 738

5mm
10mm

Available in 100m Lengths EPDM Solid

KRE 740

36mm
5mm

Available in 100m Coils EPDM Solid

Drawings are to scale

Rubber & PVC Extrusions

<h3>KRE 743</h3>  <p>27mm 31mm</p> <p>Available in 25m Coils</p> <p>EPDM Solid</p>	<h3>KRE 747</h3>  <p>13mm 8.5mm</p> <p>Available in 50m Coils</p> <p>EPDM Solid</p>	<h3>KRE 748</h3>  <p>9mm 18mm</p> <p>Available in 50m Coils</p> <p>EPDM Solid</p>
<h3>KRE 751</h3>  <p>18mm 6mm</p> <p>Available in 30m Coils</p> <p>EPDM Solid</p>	<h3>KRE 752</h3>  <p>14mm 17.5mm</p> <p>Available in 50m Coils</p> <p>EPDM Solid</p>	<h3>KRE 754</h3>  <p>7mm 12mm</p> <p>Available in 50m Coils</p> <p>EPDM Solid</p>
<h3>KRE 755</h3>  <p>6mm 11mm</p> <p>Available in 50m Coils</p> <p>EPDM Solid</p>	<h3>KRE 756</h3>  <p>17mm 4.5mm</p> <p>Available in 50m Coils</p> <p>EPDM Solid</p>	<h3>KRE 757</h3>  <p>5mm 16mm</p> <p>Available in 50m Coils</p> <p>EPDM Solid</p>
<h3>KRE 758</h3>  <p>15mm 7mm</p> <p>Available in 50m Coils</p> <p>EPDM Solid</p>	<h3>KRE 759</h3>  <p>9.5mm 9.5mm</p> <p>Aperture 1.6mm</p> <p>Available in 50m Coils</p> <p>EPDM Solid</p>	



seal the deal with a name you can trust

Rubber & PVC Extrusions

PVC 'U' Channels

KRE 761

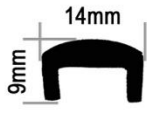

Available in
50m Coils

EPDM Solid

GS 1

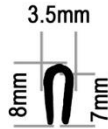

1mm - 2mm
Panel

Available in
50m Coils

Black PVC
70.Sh.A

GS 2

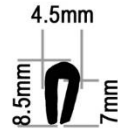

1.5mm - 2.8mm
Panel

Available in
50m Coils

Black PVC
70.Sh.A

KRE 762

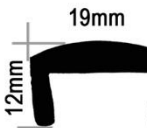

Available in
50m Coils

EPDM Solid

GS 3

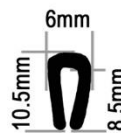

2.7mm - 3.8mm
Panel

Available in
50m Coils

Black PVC
70.Sh.A

GS 4

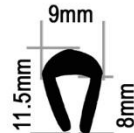

3.7mm - 5.2mm
Panel

Available in
25m Coils

Black PVC
70.Sh.A

GS 5

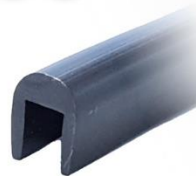
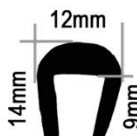

5.3mm - 6.8mm
Panel

Available in
25m Coils

Black PVC
70.Sh.A

GS 6

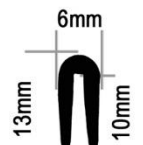

1mm - 2mm
Panel

Available in
50m Coils

Black PVC
70.Sh.A

*Drawings are
to scale*



Flock Channels

Manufactured using EPDM these flock lined window rubbers are extruded in either flat or preformed channels. They will accommodate glass from 3.5mm - 6mm thick. The flock coating will ensure that your windows slide with ease.

KR 521



8.5mm
8.5mm

100m Coils EPDM Solid with flock covering

KR 602



8.8mm
11.7mm

50m Coils EPDM Solid with flock covering

KR 603

14 A 7167



10mm
22mm

Mini Part 1310mm Lengths EPDM Solid with flock covering

KR 604

PAM 3076 & 7



12.5mm
21mm

Mini Part PAM 3076 - R/H 3077 - L/H 2100mm Lengths EPDM Solid with flock covering

KR 605



13mm
6mm
6mm
22mm

50m Coils EPDM Solid with flock covering

KR 606



10mm
26mm
14mm Fitted

50m Coils EPDM Solid with flock covering

KR 607



8mm
30mm
18mm Fitted

50m Coils EPDM solid with flock covering

KR 809



7mm
21mm

50m Coils EPDM Solid with flock covering

KR 5130



9mm
10.5mm

50m Coils EPDM Solid with flock covering

We have the manufacturing capabilities to produce bespoke flocked sections. Please be aware that due to the nature of this process minimum order quantities will apply.

For more information please get in touch with our sales team.



seal the deal with a name you can trust

Flooring & Matting

KRFM 1

3mm Fine Fluted Matting

Width: 1.22m
Length: 10m

Economy Grage
Black NR / SBR

Also available
by the Lin. metre

Normal applications include:

- Work Areas & Walkways
- Industrial Drawer Liners
- Workbenches
- Car Boot Liners
- Medium Duty Animal Matting



KRFM 2

6mm Fine Fluted Matting

Width: 1.22m
Length: 10m

Economy Grage
Black NR / SBR

Also available
by the Lin. metre

Normal applications include:

- Work Areas & Walkways
- Industrial Drawer Liners
- Workbenches
- Car Boot Liners
- Medium Duty Animal Matting



KRM 3-9

1mm - 6mm General
Purpose Plain Sheeting

Width: 1.40m
Length: 10m

Economy Grage
Black SBR / EPDM

Also available
by the metre

Excellent physical properties including:

- Abrasion resistance
- Good tensile strength
- Low compression set
- High tear properties
- Resistant to some organic solvents
and many organic salts and acids



KRM 3 1mm Thick

KRM 5 2mm Thick

KRM 7 4mm Thick

KRM 4 1.5mm Thick

KRM 6 3mm Thick

KRM 8 5mm Thick

KRM 9 6mm Thick

Plain sheeting is available in a variety of materials.
Viton, Silicone, Nitrile and Neoprene*



Flooring & Matting

KRM 10-12

3mm - 6mm Plain Insertion
Sheeting

Width: 1.40m
Length: 10m

Economy Grade
Black SBR / EPDM



Excellent physical properties including:

- Abrasion resistance
- Good tensile strength
- Low compression set
- High tear properties
- Resistant to some organic solvents and many organic salts and acids
- Added fabric reinforcement



KRM 10 3mm Thick

KRM 11 5mm Thick

KRM 12 6mm Thick



KRM 13

3.2mm Deck Top Matting

Width: 1.00m
Length: 10m

Black
Black NR / SBR

Also available
by the Lin. metre



Normal Marine applications include:

- Cabin soles
- Cockpit areas
- Foredecks
- Boarding ladder treads
- Sundecks



KRM 14

3.2mm Deck Top Matting

Width: 1.00m
Length: 10m

Coloured
Black NR / SBR

Also available
by the Lin. metre



Normal Marine applications include:

- Cabin soles
- Cockpit areas
- Foredecks
- Boarding ladder treads
- Sundecks



Available in:
Grey, Blue and Fawn



Flooring & Matting

KRM 15

3mm Broad Ribbed Matting

Width: 1.22m
Length: 10m

Black
Black NR / SBR

Also available
by the Lin. metre

Normal applications include:

- Work Areas & Walkways
- Industrial Drawer Liners
- Workbenches
- Car Boot Liners
- Light / Medium Duty Animal Matting



KRM 16

6mm Broad Ribbed Matting

Width: 1.22m
Length: 10m

Black
Black NR / SBR

Also available
by the Lin. metre

Normal applications include:

- Work Areas & Walkways
- Industrial Drawer Liners
- Workbenches
- Car Boot Liners
- Medium Duty Animal Matting



KRM 17

6mm EXTRA Broad Ribbed Matting

Width: 1.22m
Length: 10m

Black
Black NR / SBR

Also available
by the Lin. metre

Normal applications include:

- Work Areas & Walkways
- Industrial Drawer Liners
- Workbenches
- Car Boot Liners
- Medium / Heavy Duty Animal Matting



KRM 18

5mm Grip Top Matting - 2 Ply

Width: 1.50m
Length: 10m

Black
Black NR / SBR

Also available
by the Lin. metre

Normal applications include:

- Horse Box Ramps
- Conveyor Belting
- Ultra non-slip flooring

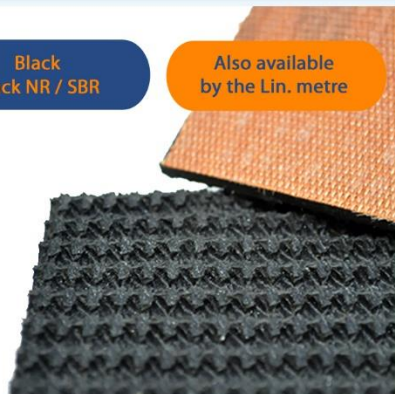



seal the deal with a name you can trust

Flooring & Matting

KRM 19

3mm Rhomboid Matting

Width: 1.22m
Length: 10m

Black
Black NR / SBR

Also available
by the Lin. metre

Normal applications include:

- Work Areas & Walkways
- Industrial Drawer Liners
- Workbenches
- Foyer Flooring
- Car Boot Liners



KRM 20

3mm Checker Plate Matting

Width: 1.22m
Length: 10m

Black
Black NR / SBR

Also available
by the Lin. metre

Normal applications include:

- Work Areas & Walkways
- Industrial Drawer Liners
- Workbenches
- Foyer Flooring
- Car Boot Liners



KRM 21

5mm Round Stud Matting

Width: 1.22m
Length: 10m

Black
Black NR / SBR

Also available
by the Lin. metre

Normal applications include:

- Work Areas & Walkways
- Industrial Drawer Liners
- Workbenches
- Foyer Flooring
- Car Boot Liners



KRM 22

3mm Pyramid Matting

Width: 1.00m
Length: 4.2m

Black
Black NR / SBR

Also available
by the Lin. metre

Normal applications include:

- Work Areas & Walkways
- Industrial Drawer Liners
- Medium Duty Animal Matting
- Anti-Slip Footwell Lining
- Car Boot Liners





Flooring & Matting

KRM 23

4mm Pyramid Matting

Width: 1.00m
Length: 4.5m

Black
Black NR / SBR

Also available
by the Lin. metre

Normal applications include:

- Work Areas & Walkways
- Industrial Drawer Liners
- Medium Duty Animal Matting
- Anti-Slip Footwell Lining
- Car Boot Liners



KRM 24

17mm Animal Matting

Width: 1.22m
Length: 1.83m

Black
Black NR / SBR

Also available
by the Lin. metre

Normal applications include:

- Heavy Duty Animal Matting

Top side provides good drainage and easy cleaning.
Lower side design offers a great aeration, allowing air to pass underneath.



KRM 25

16mm Grass Saver / Anti-Fatigue

Width: 1.00m
Length: 1.50m

80%
Recycled Rubber

Complete with
fixing pegs

Normal applications include:

- Fitness & Fun Trails
- Parks & Play Areas
- Pathways
- Warehouse / Factory Work Areas
- Swings & Climbing Areas



KRM 26

23mm Grass Saver / Anti-Fatigue

Width: 1.00m
Length: 1.50m

80%
Recycled Rubber

Complete with
fixing pegs

Normal applications include:

- Fitness & Fun Trails
- Parks & Play Areas
- Pathways
- Warehouse / Factory Work Areas
- Swings and Climbing Areas





seal the deal with a name you can trust

Flooring & Matting

KRM 27 - 30

12mm Penny Tiles - Interlocking System

Normal applications include:

- Workshops & Garages
- Gym & Fitness Centres
- Exhibitions & Events
- Games Rooms
- Factories & Showrooms

Key Benefits:

- Extremely hard-wearing
- Resistant to most chemicals
- Reduces damage caused by impact
- Good anti-fatigue properties
- Quick and simple to install
- Protects your existing floor from damage
- Eliminates dust generated by old concrete floors
- 10 year product guarantee

Width: 500mm
Length: 500mm

80%
Recycled Rubber

Available in
various designs

Tile edges
available



KRM 27 BLACK

KRM 28 GREY

KRM 29 COLOURS

KRM 30 EDGES



KRM 31

Deck Tiles - Interlocking Design

Normal applications include:

- Fitness & Fun Trails
- Parks & Play Areas
- Pathways
- Warehouse / Factory Work Areas
- Swings and Climbing Areas

Width: 500mm
Length: 500mm

80%
Recycled Rubber

Complete with
fixing pegs



KRM 32

Deck Tiles - Interlocking Design

Normal applications include:

- Over-spill Car Parks
- Drives, Paths & Cycle Routes
- Outdoor Events & Festivals
- Golf Courses & Sports Facilities
- Construction Sites

Width: 500mm
Length: 500mm

100%
Recycled Material

Oil & Chemical
Resistant





Flooring & Matting

KRM 33 - 36

Leather Lock - Interlocking Design

Width: 500mm
Length: 500mm

100%
Recycled Material

Normal applications include:

- Garages
- Sports & Leisure facilities
- Schools
- Warehouses and Factories
- Exhibitions & Events

KRM 33 BLACK
 KRM 34 GREY
 KRM 35 BLUE
 KRM 36 EDGES

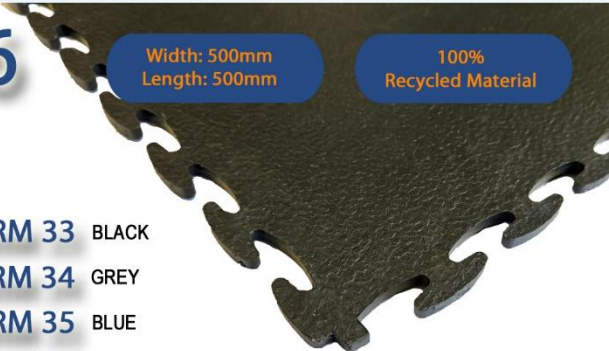

KRM 37

Ground Mesh

Width: 2mm
Length: 30m

HDPE
Plastic

Hole Size
24mm

Normal applications include:

- Grassed pedestrian areas

Key Fetures

- Easy and quick to install
- Grass will grow through the mesh to return to a lush natural green

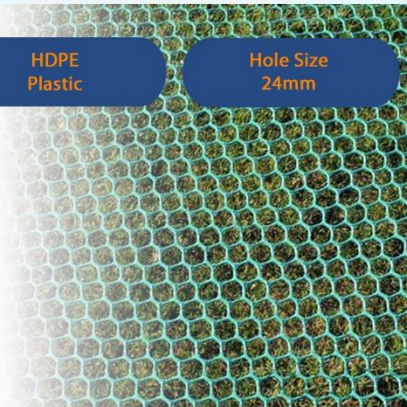

KRM 38

Play Tiles

Size:
1m /Sq

Made from 90%
recycled material

Porous, durable and
slip resistant

Normal applications include:

- Play Areas and Fitness Rooms

Key Fetures

- Easy and quick to install
- DDA approved
- Great thermal properties



KRM 39

Heron Rib

0.5m, 1m or 1.22m
wide x 10m Length

Robust, UV resistant
non-porous PVC

Various colours &
patterns available

Normal applications include:

- Sports and Leisure wet areas

Key Fetures

- Exceptionally warm and comfortable
- 4 way quick drainage and anti-bacterial
- Quick and easy to install

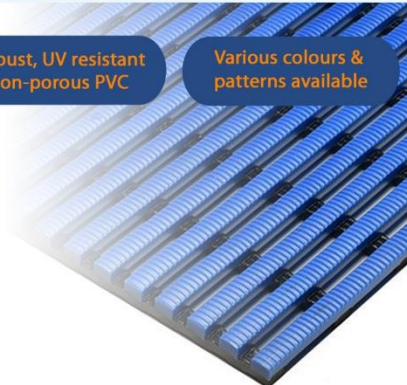



seal the deal with a name you can trust

Flooring & Matting

KRM 40 - 44 Electrical Matting

Available in different widths

Black Natural Rubber

IEC 61111 2009

Normal applications include:

- Switch Rooms
- Transformers
- High Voltage areas

Key Fetures

- Supplied in 3 different widths
- Robust and easy to install
- Fluted surface for easy cleaning

KRM 40 CLASS 0 WORKING VOLTAGE 1,000 Volts

KRM 41 CLASS 1 WORKING VOLTAGE 7,500 Volts

KRM 42 CLASS 2 WORKING VOLTAGE 17,000 Volts

KRM 43 CLASS 3 WORKING VOLTAGE 26,500 Volts

KRM 44 CLASS 4 WORKING VOLTAGE 36,000 Volts



ELECTRICAL MATTING



Bespoke Manufacturing

Over the last three decades, Kingfisher Rubber & Plastics have met the somewhat complex requirements of our customers.

If our standard stock items in this catalogue do not meet your sealing requirements, we have access to the latest production processes and manufacturing techniques to be able to offer you a solution.

Our methods include:

- ***Solid & Sponge Extrusion***
- ***Single & Multi Cavity Moulding***
- ***Waterjet Cutting***
- ***Press & Kiss Cutting***
- ***Routing***
- ***3D Prototype Printing***



From support during the design phase and selecting the correct materials; to sampling and bulk production, it would be advantageous to let Kingfisher help you from the very start of your project.



Puncture Preventative

GOOP is a tried and tested formula, having been successfully used in many different applications for more than 20 years.

It will continue to work no matter how many punctures you may experience. GOOP is an Aqueous Glycol solution (non-toxic) and contains finely cut rubber particles.

Unlike other puncture preventatives, GOOP's Key features include:

Available for all pneumatic tyres from wheel barrows to heavy plant machinery.

Goop will not freeze and remains stable even at high temperatures.

Leaves no sticky residue when a new tyre or tube is fitted.

Works effectively in both tubed and tubeless tyres.

Lasts for the lifetime of the tyre or tube.

Simply washes away with water.



Available in
250ml, 500ml
and 1 Ltr
bottles



Tools & Adhesives

We stock a range of tools and adhesives to aid in the fitment of our seals.

KRT 100



150mm Vernier

KRT 101



Standard Window Fitting Tool

KRT 102



Gel Pen Vernier Caliper

KRT 103



Rubber Profile Cutter

KR PB 20g



Cyanoacrylate
Supplied in boxes of
25 bottles or 20g bottles

KR ADH2



Adhesive Remover
Box of 50 pads

Self Adhesive Backed EPDM Strips

Our range of self adhesive backed materials are used to create a watertight seal in a huge variety of applications.

Below are our standard stock sizes which are readily available, however we can cater for almost any thickness or width.

The standard EPDM / Neoprene strips are supplied in 10m lengths, however thicker rolls may be available in 5m lengths. Plain strips are also available. Please contact us for more information.

1.5mm THICKNESS	
Part No.	Width (mm)
KRDM 25/1.5	25
KRDM 31/1.5	31
3mm THICKNESS	
Part No.	Width (mm)
KRDM 6/3	6
KRDM 9/3	9
KRDM 12/3	12
KRDM 15/3	15
KRDM 19/3	19
KRDM 20/3	20
KRDM 25/3	25
KRDM 31/3	31
KRDM 38/3	38
4mm THICKNESS	
Part No.	Width (mm)
KRDM 15/4	15
KRDM 25/4	25
5mm THICKNESS	
Part No.	Width (mm)
KRDM 10/5	10
KRDM 20/5	20
KRDM 25/5	25
KRDM 35/5	35
KRDM 50/5	50
KRDM 75/5	75
6mm THICKNESS	
Part No.	Width (mm)
KRDM 6/6	6
KRDM 10/6	10
KRDM 12/6	12
KRDM 15/6	15
KRDM 20/6	20
KRDM 25/6	25
KRDM 40/6	40
KRDM 50/6	50

7.5mm THICKNESS	
Part No.	Width (mm)
KRDM 11/7.5	11
KRDM 30/7.5	30
8mm THICKNESS	
Part No.	Width (mm)
KRDM 15/8	15
KRDM 20/8	20
KRDM 25/8	25
KRDM 30/8	30
10mm THICKNESS	
Part No.	Width (mm)
KRDM 10/10	10
KRDM 12/10	12
KRDM 15/10	15
KRDM 19/10	19
KRDM 28/10	28
KRDM 30/10	30
KRDM 45/10	45
KRDM 50/10	50
12mm THICKNESS	
Part No.	Width (mm)
KRDM 12/12	12
KRDM 15/12	15
KRDM 20/12	20
KRDM 25/12	25
KRDM 30/12	30
KRDM 50/12	50
15mm THICKNESS	
Part No.	Width (mm)
KRDM 15/15	15
KRDM 19/15	19
KRDM 25/15	25
KRDM 38/15	38

If you require a bespoke size that isn't listed, the reference chart below will help you to determine the approximate amount of 10m coils we would have to produce as a minimum.

Reference Chart	
Strip Width (mm)	Yield (Coils)
6	166
10	100
15	66
20	50
25	40
30	33
35	28
40	25
45	22
50	20
55	18
60	16
65	15
70	14
75	13
80	12
85	11
90	11
95	10
100	10

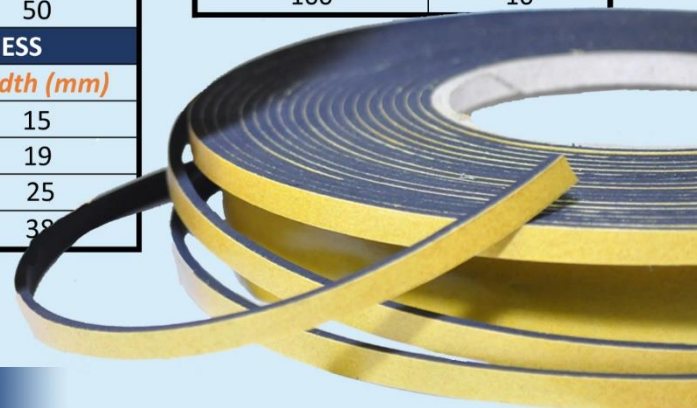



Gaskets & Sheets

Our custom gaskets can be manufactured to order. We have the capability and manufacturing techniques to supply single one off gaskets, to bulk runs comprising of thousands of gaskets at any one time. No job is too big or too small. We can supply either Self Adhesive Backed (SAB) gaskets or plain backed gaskets.

We stock a large range of plain and self adhesive materials to manufacture your gaskets, all you need to do is either send us a drawing or sample and we can do the rest...

As well as being UV, oil and chemical resistant, we can supply materials that comply with the following:

FMVSS - 302

The Federal Motor Vehicle Safety Standard No. 302 specifies the burn resistance requirements for materials used in the occupant compartments of motor vehicles.

EN 14304

European Standard specifying the requirements for foam products which are used for the thermal insulation of building equipment and industrial installations.

UL 94

A plastics flammability standard released by the U.S Underwriters Laboratories. The standard classifies plastics according to how they burn in various orientations and part thicknesses.

BS 6853

Railway fire precautions regarding the design and manufacture of passenger trains.

EN 45545-2

This is a European railway standard for fire safety which applies to all rail vehicles.

FDA

FDA compliant materials are those that are safe for direct food contact. This is any material that comes into contact with or is used for manufacturing, packaging or transporting food.

LUL

These are mandated regulations that are in force on the London Underground and must comply to specific provisions.

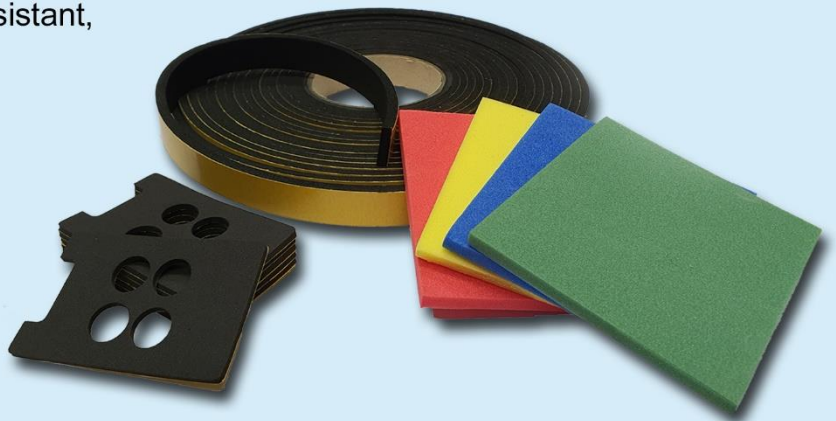

We can manufacture from the following materials:

RUBBER POLYMERS

Commercial Quality Rubber

Insertion Rubber

EPDM

L.S.L.T EPDM

Silicone

Nitrile

Viton

Cork

HIPS

SPONGE & FOAM

Neoprene

Expanded EPDM

Polyurethane

Polyethylene

Silicone Sponge

PVC Nitrile

Acoustic Foam



seal the deal with a name you can trust



The industries we supply

Kingfisher Rubber & Plastics have supplied stock and bespoke parts into many industries, in many countries around the globe over many years.

Having access to the most up to date manufacturing processes, we will always endeavour to supply whatever our customers require.

For more information on the sectors we supply simply scan the QR Code below and visit the industries page.



Tolerance Charts

As with any process in manufacturing, the production of rubber components are subject to standard tolerances. The tables below state the tolerances Kingfisher adheres to. These are specified within the International Organization for Standardization ISO 3302-1 2014.

EXTRUSIONS

Nominal Dimensions ↓		Class E1	Class E2	Class E3
Above (mm)	Up to (mm)	+/- (mm)	+/- (mm)	+/- (mm)
0	1.5	0.15	0.25	0.40
1.5	2.5	0.20	0.35	0.50
2.5	4.0	0.25	0.40	0.70
4.0	6.3	0.35	0.50	0.80
6.3	10.0	0.40	0.70	1.00
10.0	16.0	0.50	0.80	1.30
16.0	25.0	0.70	1.00	1.60
25.0	40.0	0.80	1.30	2.00
40.0	63.0	1.00	1.60	2.50
63.0	100.0	1.30	2.00	3.20
100	-	1.3%	2%	3.2%



CUT LENGTHS

Nominal Length ↓		Class L1	Class L2	Class L3
Above (mm)	Up to (mm)	+/- (mm)	+/- (mm)	+/- (mm)
0	40	0.7	1.0	1.6
40	63	0.8	1.3	2.0
63	100	1.0	1.6	2.5
100	160	1.3	2.0	3.2
160	250	1.6	2.5	4.0
250	400	2.0	3.2	5.0
400	630	2.5	4.0	6.3
630	1000	3.2	5.0	10.0
1000	1600	4.0	6.3	12.5
1600	2500	5.0	10.0	16.0
2500	4000	6.3	12.5	20.0
4000	-	0.16%	0.32%	0.50%



Although we will always endeavour to adhere to these tolerances, in some cases we may have to offer you alternate ones. This will be stated before production.



Conversion Charts

Length

For cut lengths of edge trims, door seals or extrusions

mm	Cm	Inch	Foot	Mtr	Yard
10	1	0.39	0.03	0.01	0.01
50	5	1.97	0.16	0.05	0.05
100	10	3.94	0.33	0.10	0.11
150	15	5.91	0.49	0.15	0.16
200	20	7.87	0.66	0.20	0.22
250	25	9.84	0.82	0.25	0.27
300	30	11.81	0.98	0.30	0.33
350	35	13.78	1.15	0.35	0.38
400	40	15.75	1.31	0.40	0.44
450	45	17.72	1.48	0.45	0.49
500	50	19.69	1.64	0.50	0.55
550	55	21.65	1.80	0.55	0.60
600	60	23.62	1.97	0.60	0.66
650	65	25.59	2.13	0.65	0.71
700	70	27.56	2.30	0.70	0.77
750	75	29.53	2.46	0.75	0.82
800	80	31.50	2.62	0.80	0.87
850	85	33.46	2.79	0.85	0.93
900	90	35.43	2.95	0.90	0.98
950	95	37.40	3.12	0.95	1.04
1000	100	39.37	3.28	1.00	1.09
2000	200	78.74	6.56	2.00	2.19
3000	300	118.11	9.84	3.00	3.28
4000	400	157.48	13.12	4.00	4.37
5000	500	196.85	16.40	5.00	5.47
6000	600	236.22	19.69	6.00	6.56
7000	700	275.59	22.97	7.00	7.66
8000	800	314.96	26.25	8.00	8.75
9000	900	354.33	29.53	9.00	9.84
10000	1000	393.70	32.81	10.00	10.94

Area

For flooring and matting

M ²	Ft ²	Yard ²
1	10.76	1.20
5	53.82	5.98
10	107.64	11.96
15	161.46	17.94
20	215.28	23.92
25	269.10	29.90
50	538.20	59.80
100	1076.40	119.60
200	2152.80	239.20
300	3229.20	358.80
400	4305.60	478.40
500	5382.00	598.00
600	6458.40	717.60
700	7534.80	837.20
800	8611.20	956.80
900	9687.60	1076.40
1000	10764.00	1196.00

Weather Strips

For weather strips and glazing rubbers

Fraction	mm
1/16	1.56
1/8	3.18
3/16	4.8
1/4	6.4
5/16	7.94
3/8	9.5
7/16	11.1
1/2	12.7
9/16	14.3
5/8	15.9

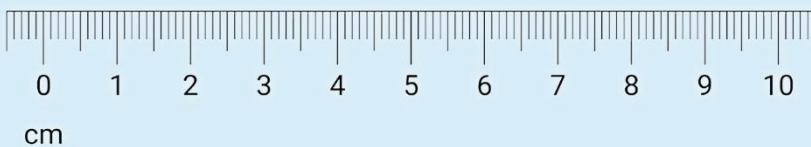

Classic Car Parts

Over the years Kingfisher have built up a range of classic car parts, from chrome grill surrounds and screen seals, to headlamp and fuel cap gaskets. Below is a list of our standard Mini parts. We do have the capability to produce parts for Jaguar, Landrover, Triumph, Morris Minor, MG, Lotus, TVR and Jensen.

PART & DESCRIPTION

Part No.	Description
JRC 2671 (JPC 4834)	Front Screen Seal (1959-91)
JRC 2673	Fixed Rear Quarter Light Mk 3 Onwards Non opening
JRC 2674	Rear Screen Seal (1968-2000)
JRC 7008	Bonnet Seal, Rear drain channel (KR 117)
JRC 7898	Bonnet Seal Drip Rail (KR 008)
CCB100130	Front Screen Seal Mk 3/4/5
CFB 10047	Door Seal Mk 3
14A 6584	Boot Seal 1958 – 1976 KRS 25 (2430mm)
14A 7167	Door Channel Upper MK1&2 Van & Estate KR 603 (1310mm)
14A 7210	Classic Mini Van/Estate Rear Door Window
14A 7286	Mini Radiator Surround MK1&2 and Early MK3
14A 7608	Classic Mini Van/Estate Rear Door Seal (R/H)
14A 7609	Classic Mini Van/Estate Rear Door Seal (L/H) SPLIT SEAL
14A 8744	Rear Screen Seal MK 1
24A 1351	Door Seal MK 1
24A 1466	Front and Rear Chrome Filler (KR 328) 3.28m
24A 2708M	Top Grill Trim MK3 (1970)
37H 8108M	Chrome Surround Seating Strip MK 2 Onwards

PART & DESCRIPTION

Part No.	Description
XFH 100460	Lamp Lens Gasket MK4
CKE 10018	Boot Lid Seal MK4
ALA 5748	Door Glass Support MK3
ALA 5897	Mini Quarter Light MK1
PAM 1019	Opening Rear Quarter Light Mk 3 (1976 Onwards) Opening
PAM 3076	Classic Mini Winding Window MK3 (Right Hand)
PAM 3077	Classic Mini Winding Window MK3 (Right Hand)
KR 401	Standard Wheel Arch Moulding (Chrome)
KR 402	<i>Deluxe</i> Wheel Arch Moulding (Chrome)
KR 402/B	<i>Deluxe</i> Wheel Arch Moulding (Black)
KR 760/B	Mini Gutter Trim (Black)
KR 760/C	Mini Gutter Trim (Chrome)
GS 1	U Channel (1 - 2mm)
GS 2	U Channel (1.5 - 2.8mm)
GS 6	U Channel Long Leg (1-2mm)
KRE 718	Large Tadpole Section
KRE 724	Small Tadpole Section
KRT 101	Window Fitting Tool



Useful Information

Here's our easy to follow reference guide to assist you in finding the best seal for your requirements. Find your panel thickness then the seal range you require for the profile that will be the closest match for your needs. Don't forget, samples are available if required.

TOP SEALS

Max. Seal Range→ Panel↓	6mm	10mm	11mm	15mm	16mm	17mm	17.5mm	22mm	23mm	27mm	33mm	35mm	41mm
1mm – 2.5mm	x	x	x	x	x	x	x	x	x	KR 028	x	x	x
1mm – 3mm	x	KR 119 KR 008	x	KR 003	x	KR 009	x	x	x	x	x	x	x
1.5mm – 3mm	KR 036	x	x	x	x	x	x	x	x	x	x	x	x
1.5mm – 3.5mm	x	KR 055	x	x	x	x	x	KR 031	x	x	x	x	KR 022
1.5mm - 4mm	x	x	x	x	x	x	x	x	x	x	KR 044	x	x
2mm – 3mm	x	x	x	x	x	x	KR 117	x	KR 054	x	x	x	x
2mm x 5mm	x	x	x	x	x	x	x	x	x	x	x	KR 047	x
4mm – 6mm	x	x	KR 056	x	KR 032	x	x	x	x	x	x	x	x
Slide in 6mm	x	x	KR 029	x	x	x	x	x	x	x	x	x	x
Slide in 11.5mm	x	x	KR 006	x	x	x	x	x	x	x	x	x	x

SIDE SEALS

Max. Seal Range→ Panel↓	10mm	11mm	16mm	18mm	19mm	20mm	23mm	26mm	29mm	31mm
1mm – 2mm	KR 040	x	x	x	x	x	x	x	x	x
1.5mm – 2.5mm	x	x	KR 005	x	x	x	x	x	x	x
1.5mm – 3mm	KR 058	KR 116 KR 057	x	KR 007	KR 042 KR 118	KR 038 KR 002/R	KR 025	x	KR 035	x
2mm – 3mm	x	x	KR 010	KR 046	x	x	x	KR 011	x	x
3mm – 5mm	x	x	x	x	x	x	x	x	x	KR 037
4mm – 6mm	x	x	x	x	x	KR 115	x	x	x	x



Basic Material Specifications

Below is some basic information for just a few of the more common materials we use in our products. Specific data sheets are available from our website and on request.

EPDM (Ethylene Propylene Diene Monomer)

A type of synthetic rubber that has superior resistance to heat, light, and ozone exposure. For this reason they are useful in external harsh environments and are used in many applications. We can also offer a Low Smoke Low Toxic grade of EPDM
Typical temperature range: -20°C to +90°C

NITRILE

A type of synthetic rubber also known as NBR. Nitrile is resistant to oil, fuel, and other chemicals making it the ideal material for Automotive and Aerospace applications.
Typical temperature range: -35°C to +120°C

SILICONE RUBBER

Silicone rubber is an elastomer rubber. It is generally non-reactive, stable, and resistant to extreme environments while still maintaining its useful properties. Due to these properties and its ease of manufacturing and shaping, silicone rubber can be found in a wide variety of products, including: voltage line insulators; automotive applications; cooking, baking, and food storage products; electronics and medical applications.
Typical temperature range: -55°C to +300°C

PVC (Polyvinyl Chloride)

PVC comes in two basic forms: rigid (sometimes abbreviated as RPVC) and flexible PVC. Flexible PVC provides a good balance of tensile strength, tear resistance, and weatherability and it is very popular due to its versatility.
Typical temperature range: -60°C to +105°C

NEOPRENE

Neoprene is a synthetic rubber that has good chemical stability and maintains flexibility over a wide temperature range. It has good resistance to chemicals, water, heat, flames, oxygen and ozone. The material also reacts well against weathering and sunlight. This means that the material ages well.
Typical temperature range: -20°C to +110°C

As well as the above materials we also produce parts using Polyethylene, Natural Rubber, Cork, Felt, Fibreboard HIPS, Nitrile PVC and Santoprene among others.

Please get in touch for more information.



seal the deal with a name you can trust



PLACING AN ORDER...

We can process orders placed by email, telephone, or through our website. All orders are processed immediately and stock items will usually be dispatched within 24 hours. Non-stock items normally take a little longer, but we will notify you if we expect any delay. Incoming calls out of normal office hours will be diverted to our answerphone, please leave a message and a member of staff will return your call as soon as possible.

MAKING A PAYMENT...

We can process your payment over the telephone using a Credit / Debit card, or we can send over a proforma invoice and payments can be made via BACS. We also offer customers the opportunity to open a 30 day Credit Account after satisfactory references have been received.

SHIPPING AND TRACKING...

We operate standard prices for part cost carriage, the most up to date information can be found on our website. We send all consignments via our dedicated carrier and all consignments are fully tracked and a signature will be required. Proof Of Delivery (POD) documentation is available if required. Extra heavy, large, overseas and residential consignments will incur additional costs. Please ask for further details.

GETTING IN TOUCH...

Offices are open Monday to Thursday hours 08:00 - 17:00 and 08:00 - 13:00 on Fridays. We are also available on social media platforms and you can visit our website for more information or to chat to us online.

Our trade counter is open to the public Monday to Thursday 08:00 - 17:00 and 08:00 - 13:00 on Fridays

Scan here to
place an order

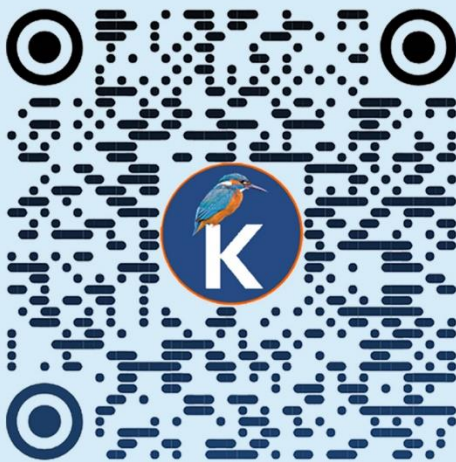

The enclosed information is given to the best of our knowledge and should be considered as guidelines not specifications. While reasonable care has been taken to ensure that all data is representative, Kingfisher Rubber & Plastics does not warrant or otherwise guarantee, expressly or impliedly, the suitability, accuracy, reliability or completeness of the information. We recommend evaluation prior to use to ascertain the suitability of the material for the application. All drawings in this brochure are represented to 1:1 scale as best as possible.

Copyright © 2024 Kingfisher Rubber & Plastics. All rights reserved.

*Seal the deal
with a name you can trust*



Kingfisher Rubber & Plastics, Units 1 & 2 Woden Court,
Saxon Business Park, Bromsgrove. Worcs
B60 4AD

T: (+44) 01527 570 570

E: sales@kingfisherrubber.co.uk

www.kingfisherrubber.co.uk

